

Seafloor™ datasheet

PicoMBES-120SF Miniature CHIRP FM Multibeam Echosounder

About

PicoMBES-120SF is a low-cost, miniature CHIRP FM multibeam echosounder (MBES), customized to fit inside the transducer well of the EchoBoat™. The EchoBoat is a 1.68m remotely controlled and autonomous surface vehicle that can be used to perform multibeam surveys in very shallow water or in remote areas where it is difficult to launch conventional survey boats.

PicoMBES-120SF features rugged, fully encapsulated transducers and an aluminum topside with optional integrated Applanix INS. All beamforming and digital signal processing are performed within the sonar, allowing a direct connection from the sonar to a computer via Ethernet, or Android smartphone/tablet via WiFi. GNSS and IMU connect to the sonar - no rack-mounted hardware is required. Android and Windows GUIs are provided for real-time display and recording. The Android app features a real-time 3D point cloud allowing bathymetric data to be acquired using a tablet or smartphone in an Aquapac.

The PicoMBES-120SF interfaces directly with the EchoBoat's onboard industrial PC. From a shore laptop using Remote Desktop Connection, the User accesses the onboard PC via a WiFi bridge to control the sonar settings, data logging, as well as the EchoBoat-ASV's AutoNav autonomous mission planner.

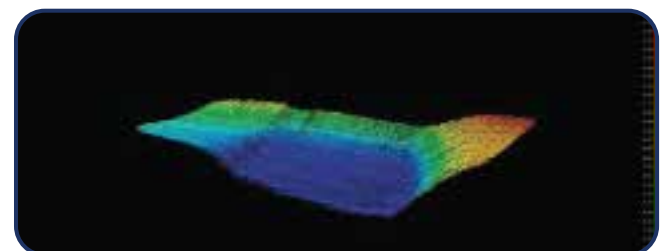
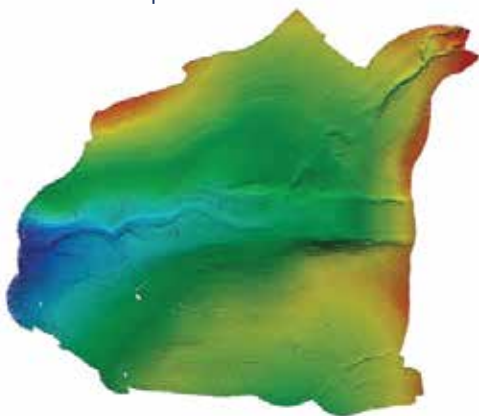

Seafloor™ datasheet

PicoMBES-120SF Miniature CHIRP FM Multibeam Echosounder

Specifications

Swath: 120°

Beam Width: Model dependant.

Center Frequency: 337 kHz, 360 kHz, 380 kHz (agile, current firmware release)

Bandwidth: 25 kHz

Depth Resolution: 37 mm

Number of Beams: 256 spaced at 0.47°

Maximum Range: 240 m

Maximum PRF: 25 Hz

Full water column visualization and data logging

Amplitude and phase detection

Electrical

- ▶ **Telemetry:** 100Mbps full-duplex Ethernet
- ▶ **ZDA + PPS, IMU:** 100Mbps full-duplex Ethernet + RS422 or RS232 + TTL (s/w selectable)
- ▶ **Power Consumption:** 13W
- ▶ **Voltage:** 24-36VDC
- ▶ **Optional integrated INS**

PicoFLS/PicoMBES MCBH8M Pinout

PIN	FUNCTION
1	0V
2	12-36V
3	RS422(A) PPS / TTL PPS
4	RS422(B) PPS / RS232 ZDA
5	100BaseT-RXD+
6	100BaseT-RXD-
7	100BaseT-TXD+
8	100BaseT-TXD-

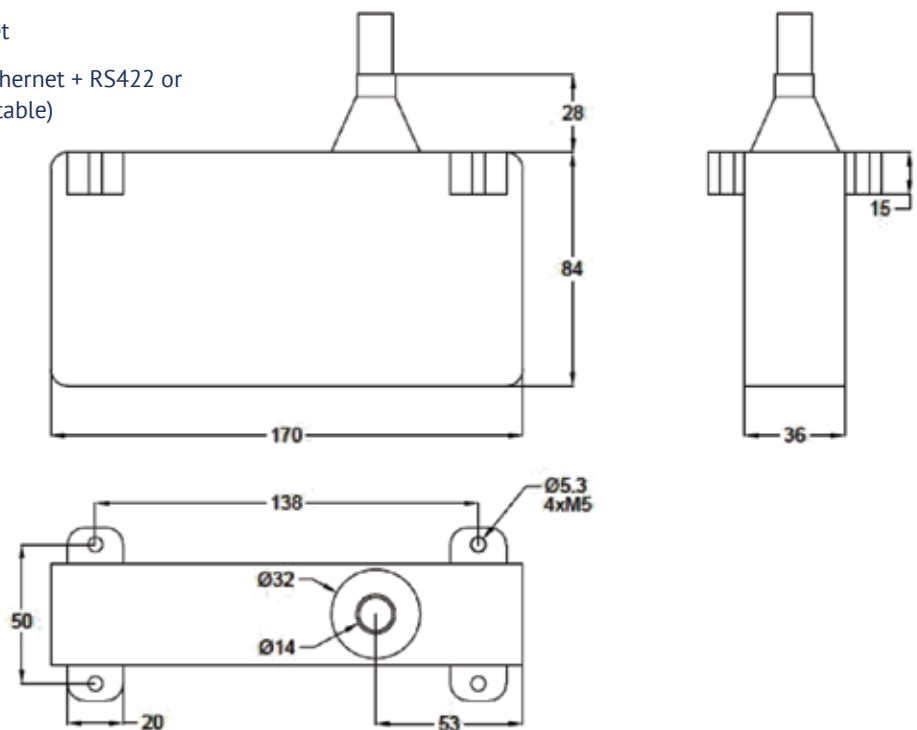

Seafloor Systems, Incorporated
4415 Commodity Way | Shingle Springs, CA 95682 | USA
530-677-1019 | info@seafloorsystems.com | www.seafloorsystems.com